

SMART™

WP VOIP PHONE

MODEL (WMHS-ERT-I)

RAIL/METRO COMMUNICATIONS SIMPLIFIED



- SIP BASED VOIP PHONE
- ROBUST HOUSING
- STAINLESS STEEL VANDALPROOF HANDSET
- VERTICAL WALL MOUNT
- KEYPAD / NON KEYPAD MODELS
- HANDSET WITH NOISE CANCELING FEATURE

SMART WEATHER PROOF TELEPHONE (WMHS-ERT-I)

The Emergency Rail Telephone is designed for use at Railway / Metro track line.

These phones are installed outdoor and are as per IP 65 standards

SMART DESIGN

Housed in weather proof aluminum Alloy die-casting body and manufactured to high standard, these telephones offer increased resistance to vandalism, and ensure that the primary function of communication is maintained at all times.

VOIP SIP PHONE

As a SIP phone can be connected to any standard IP PABX, available in dial keypad and non-dial versions.

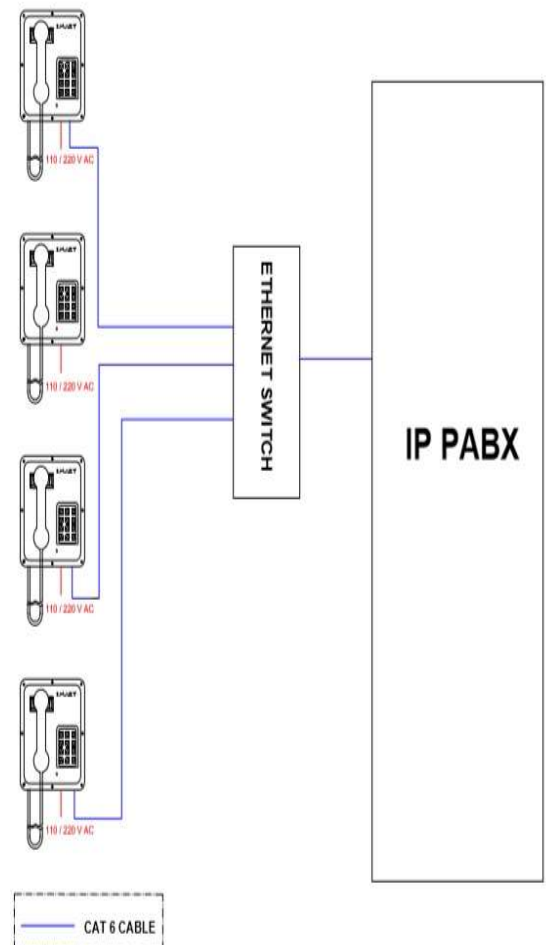

SPECIFICATIONS: -

Protocols/Standards

SIP RFC3261, TCP/IP/UDP, RTP/RTCP, HTTP/HTTPS, ARP/RARP, ICMP, DNS (A record, SRV, NAPTR), DHCP, SSH, TFTP, NTP, STUN, SIMPLE, LLDP-MED, LDAP, TR-069, 802.1x, TLS, SRTP.

Network Interfaces

10/100 Mbps RJ 45 Ethernet port.

Voice Codexs

Support for G.711 μ a, G.722 (wide-band), G.726-32, G.729 A/B, in-band and out-of-band

DTMF

(In audio, RFC2833, SIP INFO), VAD, CNG, AEC, PLC, AJB, AGC

Power Supply

Universal Power Supply Input 100-220V AC.

Temperature and Humidity

Operation: 0°C to 40°C, Storage: -10°C to 60°C, Humidity: 10% To 90% Non-condensing

Mechanical

Hook switch (magnetic reed) life

>1 000 000 operations.

Body construction

AL alloy, powder coated.

Dimensions

280X 250 X 70 mm.

Net weight

2 kgs.

Handset material

High impact ABS.

Microphone

Noise reducing dynamic.

Standard mounting

Vertical wall.

Handset cord

Stainless steel.

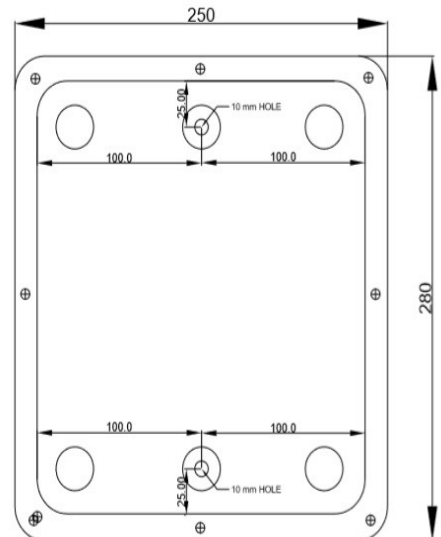
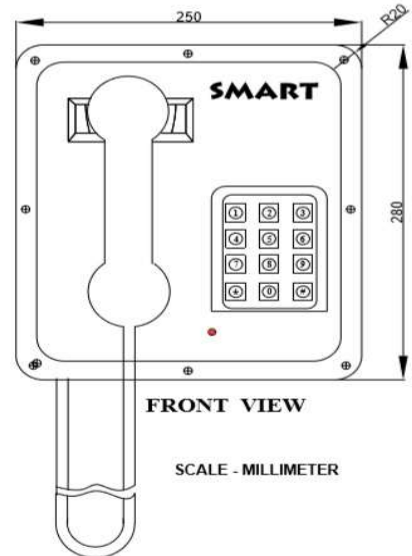

IP PHONE COMMUNICATION SCHEME FOR HIGH SPEED RAILWAY TUNNEL

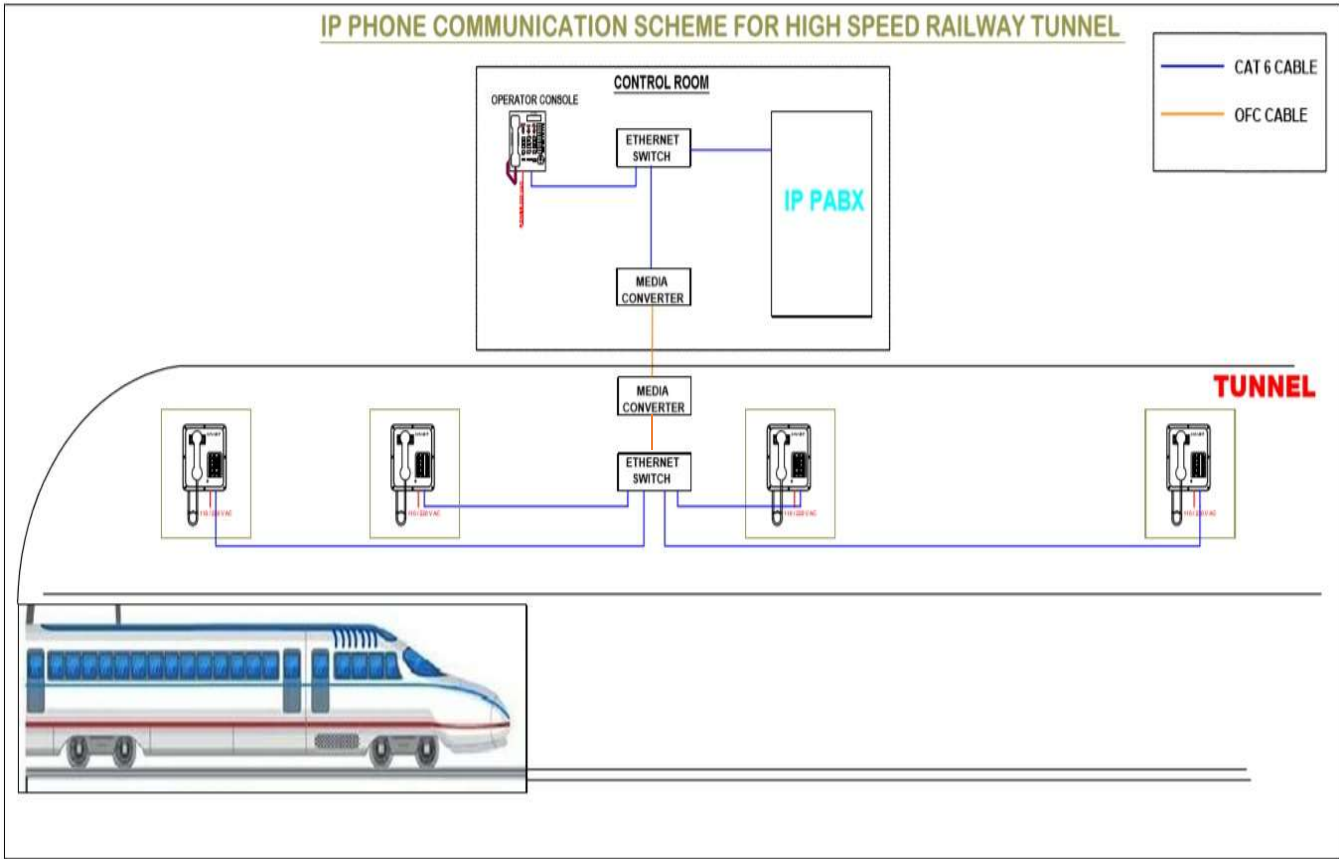

cables & wireless co.

FF 75 RAJAT ARCADE, MIDC T-POINT,
AMRAWATI ROAD, WADI,
NAGPUR -440023.MAHARASHTRA, INDIA.

PHONE:- +917104-224381
FAX:- +917104-224381.
Cell: - +9198226 95746, +919822941190

Website:- www.cnwcom.in

E-mail: - cnwcom@gmail.com.

"(Specifications and description subjected to change without prior notice)"